

GENERAL DYNAMICS
SATCOM Technologies

4096-662
May 24, 2016

ASSEMBLY MANUAL
Revision D

**1.2M Ku-BAND Rx/Tx
SERIES 1135
ANTENNA SYSTEM**

General Dynamics SATCOM Technologies
1700 Cable Drive NE
Conover NC 28613 USA
Phone 770-689-2040
www.gdsatcom.com

**1.2M Ku-BAND Rx/Tx
SERIES 1135
ANTENNA SYSTEM**

D	Add Conover Address	5/24/16	RAH
C	Changed Logo and Name	5/5/09	RAH
B	Rev. ELEVATION ROD	5/18/06	RAH
A	REVISED PER REVIEW	9/20/04	CLT
-	ORIGINAL RELEASE	8/18/04	CLT
REV.	DESCRIPTION	DATE	APPROVED

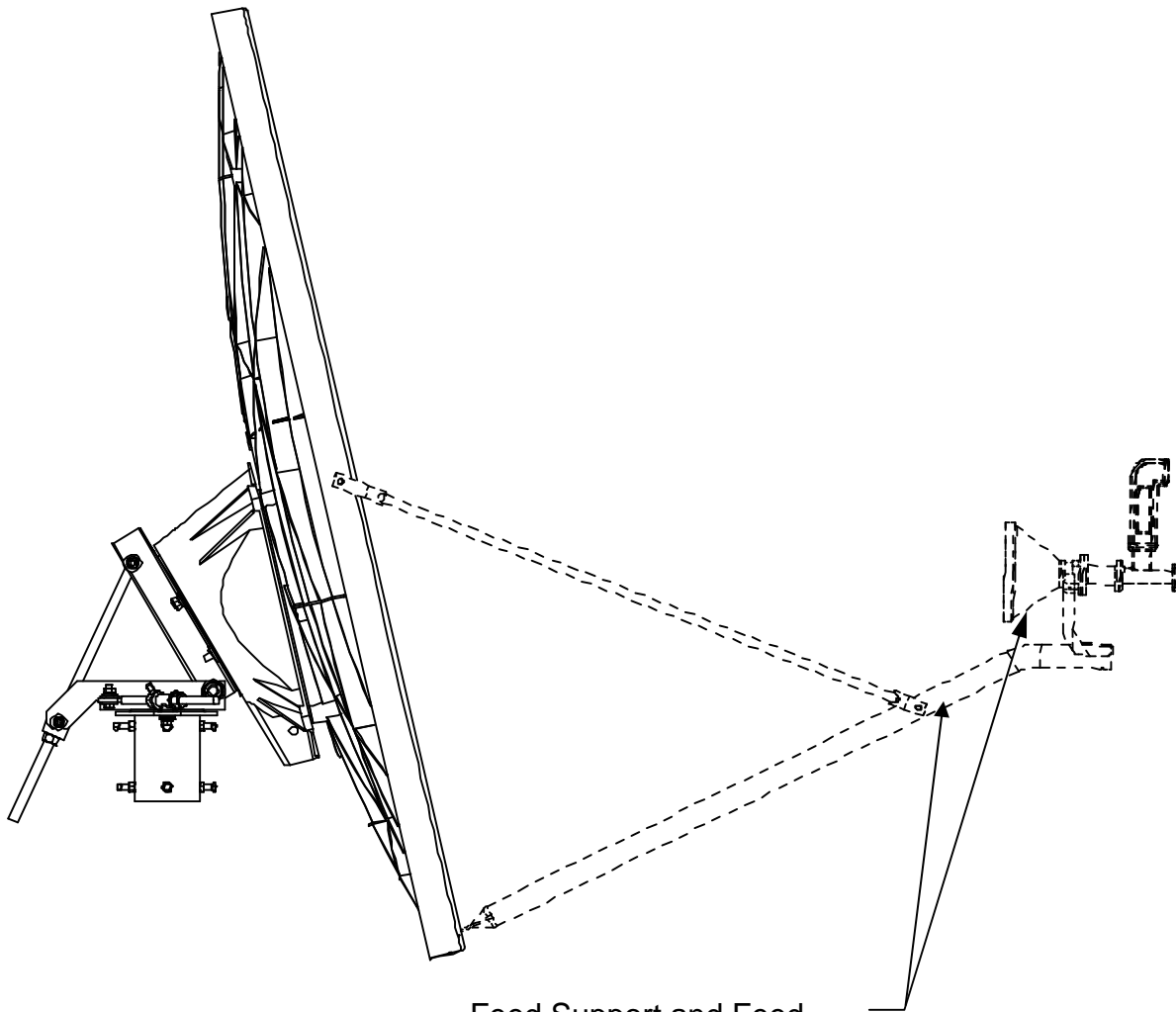

Feed Support and Feed varies. See instructions included with the feed and/or feed support.

1.2M ANTENNA SYSTEM
FIG. 1

TABLE OF CONTENTS

<u>SECTION</u>	<u>TITLE</u>
I	INTRODUCTION
1.0	GENERAL INFORMATION
1.1	UNPACKING & INSPECTION
1.2	FREIGHT DAMAGE
1.3	MATERIAL MISSING OR DAMAGED
1.4	MECHANICAL INSTALLATION TOOLS
1.5	FOUNDATION INTERFACE
II	ANTENNA SYSTEM ASSEMBLY
2.0	MOUNT ASM PARTS LIST
2.1	MOUNT ASSEMBLY
2.2	REFLECTOR ASM PARTS LIST
2.3	REFLECTOR ASSEMBLY
2.4	FEED SUPPORT AND FEED ASSEMBLY
III	SATELLITE ALIGNMENT
3.0	ANTENNA POINTING
IV	MAINTENANCE
4.0	MAINTENANCE OVERVIEW
4.1	REFLECTOR
4.2	MOUNT & REFLECTOR SUPPORT
4.3	FEED & FEED SUPPORT

SECTION I INTRODUCTION

1.0 GENERAL INFORMATION

This manual describes the assembly and installation of General Dynamics' 1.2 meter antenna systems. The General Dynamics 1.2 meter is a rugged and reliable mount, which will operate in the Ku-Band frequency with high efficiency and at the same time successfully withstand the effects of the environment. General Dynamics' 1.2 meter antennas have an F/D ratio of .8, and are commonly used with a 39° General Dynamics Feed Horn.

These instructions, listed by sections, cover all areas of assembly and installation. Additional sections are included in the manual to provide information on antenna alignment and satellite and maintenance.

1.1 UNPACKING AND INSPECTION

The system containers should be unpacked and inspected at the earliest date to insure that all material has been received and is in good condition. A complete packing list for each major component is supplied.

1.2 FREIGHT DAMAGE

Any damage to materials while in transit should be immediately directed to the freight carrier. He will instruct you on matters regarding any freight damage claims.

1.3 MATERIAL – MISSING OR DAMAGED

Any questions regarding missing or damaged materials that are not due to the freight carrier should be directed to General Dynamics' Customer Service Department at:

**General Dynamics SATCOM Technologies
1700 Cable Drive NE
Conover NC 28613 USA
Phone 770-689-2040
www.gdsatcom.com**

1.4 MECHANICAL INSTALLATION TOOLS

The hardware supplied with this antenna system is U.S. SAE standard size. However, the sizes have been chosen to allow use with compatibly sized metric wrenches as shown in the table below.

HARDWARE SIZE	SAE WRENCH SIZE	METRIC WRENCH SIZE	MAX RECOMMENDED TORQUE
5/16" Bolt	1/2"	13 mm	12 ft-lb. (16.3n-m)
3/8" Bolt	9/16"	14 mm	21 ft-lb. (28.5 n-m)
1/2" Bolt	3/4"	19 mm	51 ft-lb. (69.2 n-m))
5/8" Bolt	15/16"	24 mm	101 ft-lb. (137.0 n-m)

Also recommended for installation:

Compass - graduated to .5°
Torpedo Level
Adjustable Wrench

1.5 FOUNDATION INTERFACE

The required interface from the foundation to the mount is 2-1/2" schedule 40 pipe (2.88" O.D.) or (72mm - 74mm O.D. x 5.2mm THK) . A suggested in-ground foundation is shown in Figure 1.

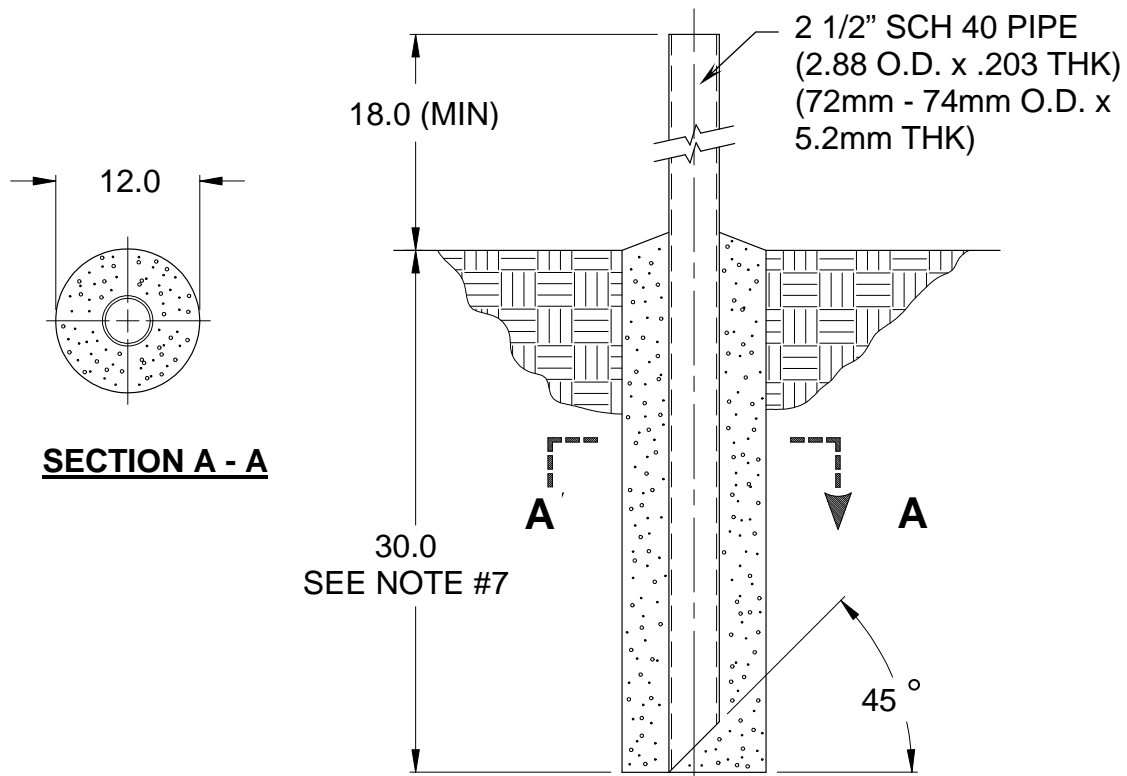

Also available from General Dynamics, as options, are a kingpost pedestal mount and non- penetrating mast mount.

SUGGESTED IN-GROUND FOUNDATION**FIG. 2****NOTES:**

1. 2 1/2" schedule 40 pipe (72mm to 74mm) should conform with ASTM A53.
2. All concrete should conform to building code standards and have a minimum compressive strength of 3000 PSI at 28 days. (Per ACI-318-77)
3. Soil bearing capacity should be no less than 2000 PSF.
4. Concrete should be poured against undisturbed soil.
5. Allow concrete 24 hours set time before installation of antenna.
6. The antenna should be properly grounded to meet applicable local codes.
7. Minimum depth as shown or extend to local frost line.
8. Foundation meets the design requirements as set forth by the uniform building code. (1982 edition)

(GENERAL DYNAMICS DOES NOT REPRESENT OR WARRANT THAT ANY PARTICULAR DESIGN OR SIZE OF FOUNDATION IS APPROPRIATE FOR ANY LOCALITY OR EARTH STATION INSTALLATION.)

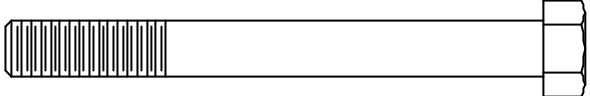
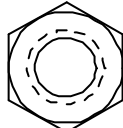
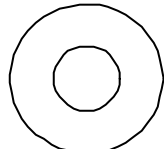
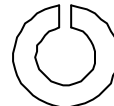
SECTION II ANTENNA SYSTEM ASSEMBLY

MOUNT ASM PARTS LIST – TABLE 2.0			
ITEM	PART NO.	DESCRIPTION	QTY
1	0185-483	Az/EI Positioner Assembly	1
2	0490-898	Elevation Adjustment Rod	1
3	8032-028	3/8-16 x 3.50 Hex Bolt 	1
4	8104-007	1/2-13 Hex Nut 	2
5	8201-042	3/8" Flatwasher 	2
6	8202-042	3/8" Lockwasher 	1
7	8102-007	3/8" Hex Nut 	1

2.1 MOUNT ASSEMBLY

CAUTION: During the assembly procedure, the sequence of instructions must be followed. **Do Not Tighten Any Hardware Until Instructed.** Refer to the parts list table and the referenced steps.

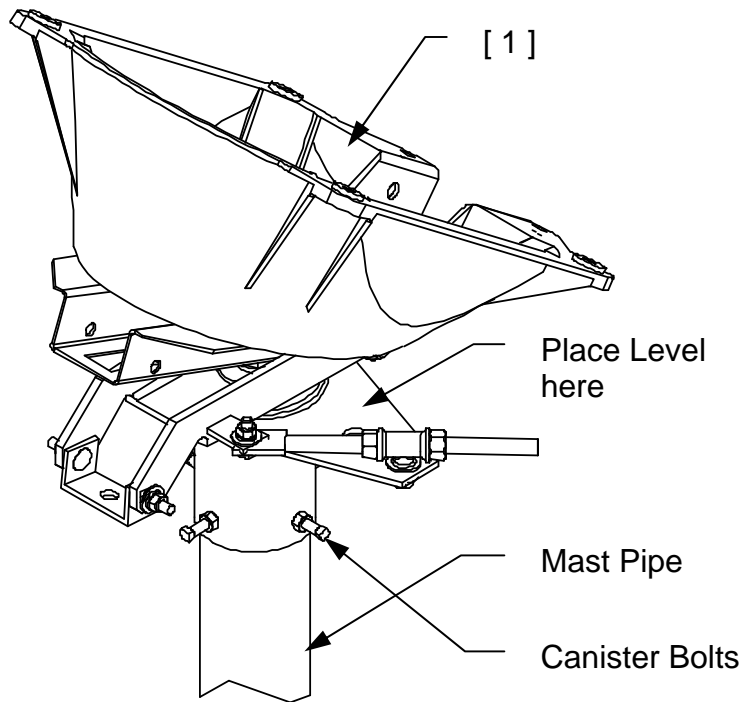

FIG. 3

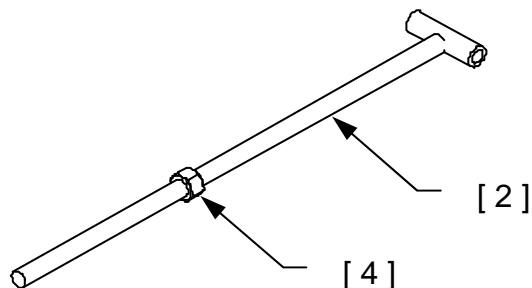

FIG. 4

STEP 1.

Slip the Az/EI Positioner (item 1) onto the mast pipe as shown. Point the Az/EI in the general direction of the satellite azimuth heading.

Place a torpedo level on the top plate of the canister. While monitoring the level, turn the canister bolts until the assembly is level and tight on the mast pipe.

STEP 2.

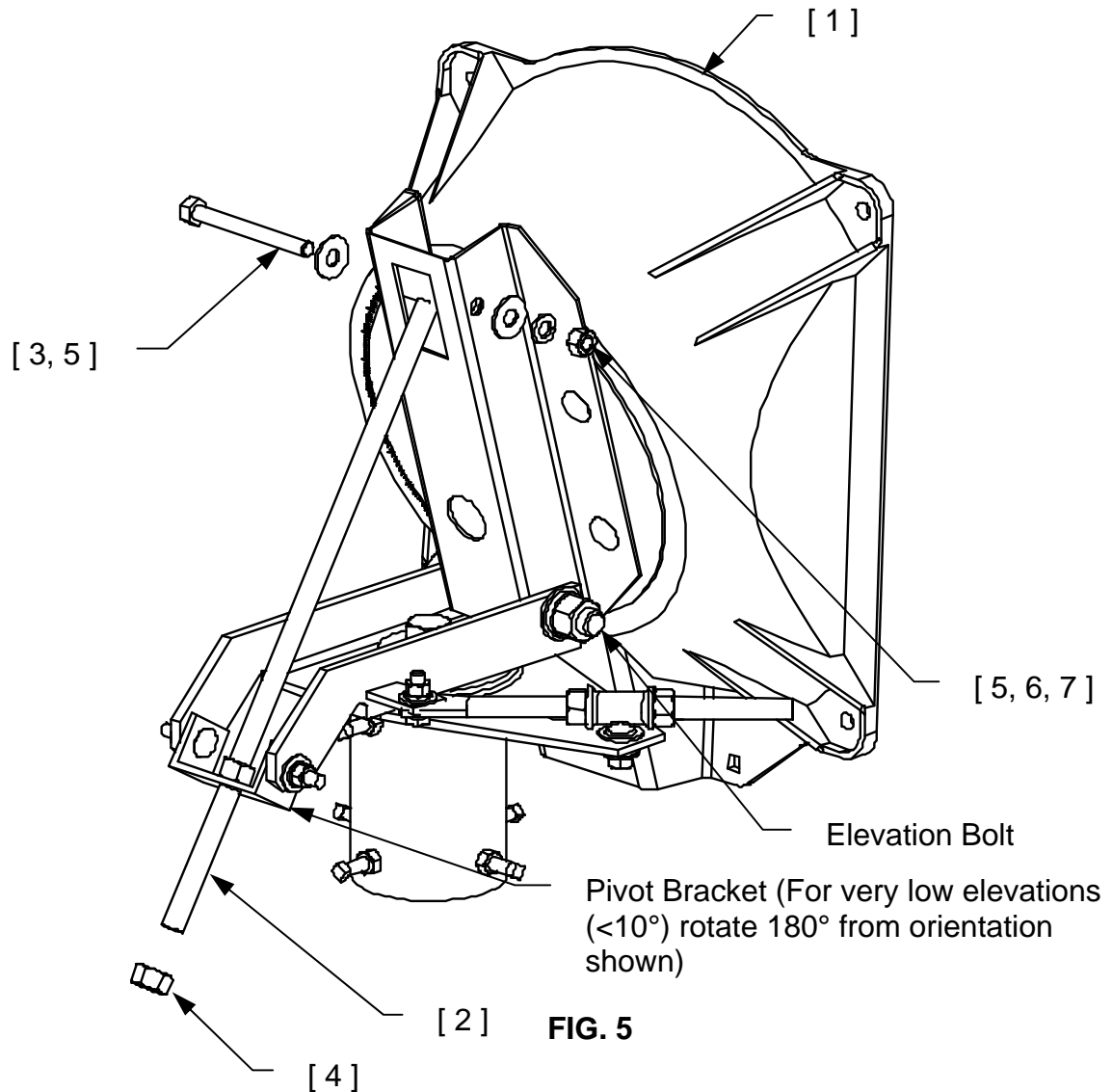

Thread one 1/2" nut (item 4) onto the Elevation Adjustment Rod (item 2) approximately 6" as shown.

**STEP 3.**

After completing step 2, loosen the Elevation Bolt and rotate the elevation setting as shown. Note that throughout this procedure, the elevation may need adjusting to allow installation of components.

Insert the Elevation Adj. Rod (item 4) into the Pivot Bracket. Thread one 1/2" nut onto the rod and lightly snug it against the Pivot Bracket.

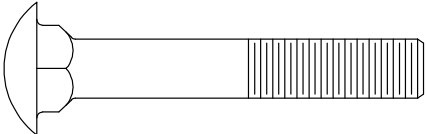
Insert the 3/8" bolt (item 3) through the washer (item 5), Az/EI (item 1), and the Elevation Adj. Rod (item 2). Secure using the 3/8" hardware provided (items 5, 6, 7).

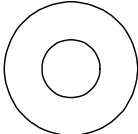
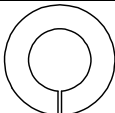
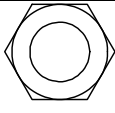
REFLECTOR ASM PARTS LIST – TABLE 2.2			
ITEM	PART NO.	DESCRIPTION	QTY
1	VARIABLES	1.2M Reflector	1
2	0185-483	Az/EI Positioner Assembly (completed from section 2.1)	1
3	8038-024	5/16" x 3.00 Carriage Bolt 	2
4	8038-026	5/16" x 3.25 Carriage Bolt 	2
5	8201-041	5/16" Flatwasher 	4
6	8202-041	5/16" Lockwasher 	4
7	8101-009	5/16" Hex Nut 	4

2.3 REFLECTOR ASSEMBLY

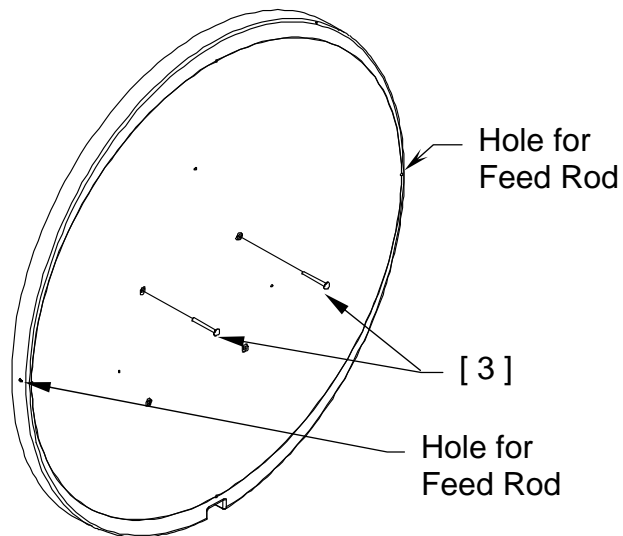

FIG. 6

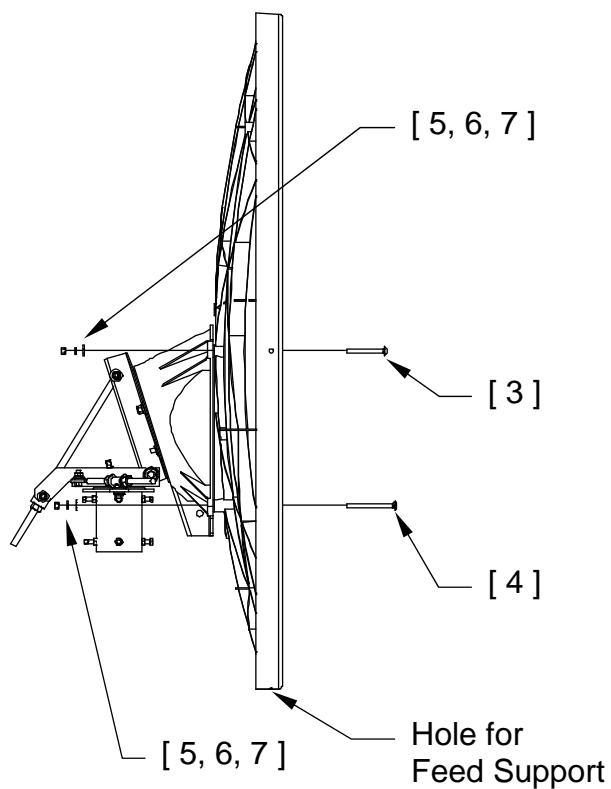

FIG. 7

STEP 1.

Stand the reflector on its bottom edge and insert two 5/16"x 3.00" carriage bolts (item 3) thru the top two holes as shown.

STEP 2.

- A) With the top two bolts in place, lift the reflector to the reflector support so that the top two bolts pass thru the two holes in the upper crossarm. Secure the two bolts with 5/16" hardware (items 5, 6, 7).
- B) Insert two 5/16"x 3.75" carriage bolts (item 4) thru the bottom two holes and secure with (items 5, 6, 7). *Tighten securely but do not over tighten as this may damage the reflector.*

2.4 FEED SUPPORT AND FEED ASSEMBLY

After completing sections 2.1 through 2.3, the feed support and feed can be installed. Feed supports and feeds vary for various applications. Refer to the manuals included with the feed support and/or feed for instructions specific to the installer's application.

SECTION III ANTENNA POINTING

3.0 ANTENNA POINTING

Note: The following alignment procedure is intended only as a general reference guide for this antenna. For proper antenna performance, accurate alignment is critical. Therefore, it is recommended that your own detailed procedure be used or contact General Dynamics' Technical Support Department for additional recommendations.

REFER TO FIG. 8 AND FIG. 9 ON THE NEXT PAGES FOR A DETAILED VIEW

- STEP 1:** Loosen the four 3/8" nuts that lock the polarization. Set the polarization for the installer's application and snug the four 3/8" nuts.
- STEP 2:** **BEFORE ADJUSTING ELEVATION LOOSEN THE HARDWARE ON BOTH SIDES OF THE POSITIONER, REFER TO FIGURE 2 FOR LOCATION.** Adjust the reflector up or down in elevation by turning the two 1/2" Nuts on the Elevation Adj. Rod until the desired elevation is achieved. The installer should use an inclinometer on the backstructure of the mount to verify the correct elevation angle. Snug the 1/2" Nuts on the Elevation Rod.
- STEP 3:** Azimuth Adjustment: With the electronics set to acquire the satellite, rotate the antenna, in azimuth, by turning the two 1/2" nuts on the Azimuth Adj. Rod until the satellite is found. Peak the antenna in azimuth and snug the 1/2" azimuth adj. nuts.
- STEP 4:** Peak the antenna signal by fine adjustments made in azimuth, elevation, and polarization until the optimum signal is achieved.
- STEP 5:** Tighten all hardware used for adjustment.

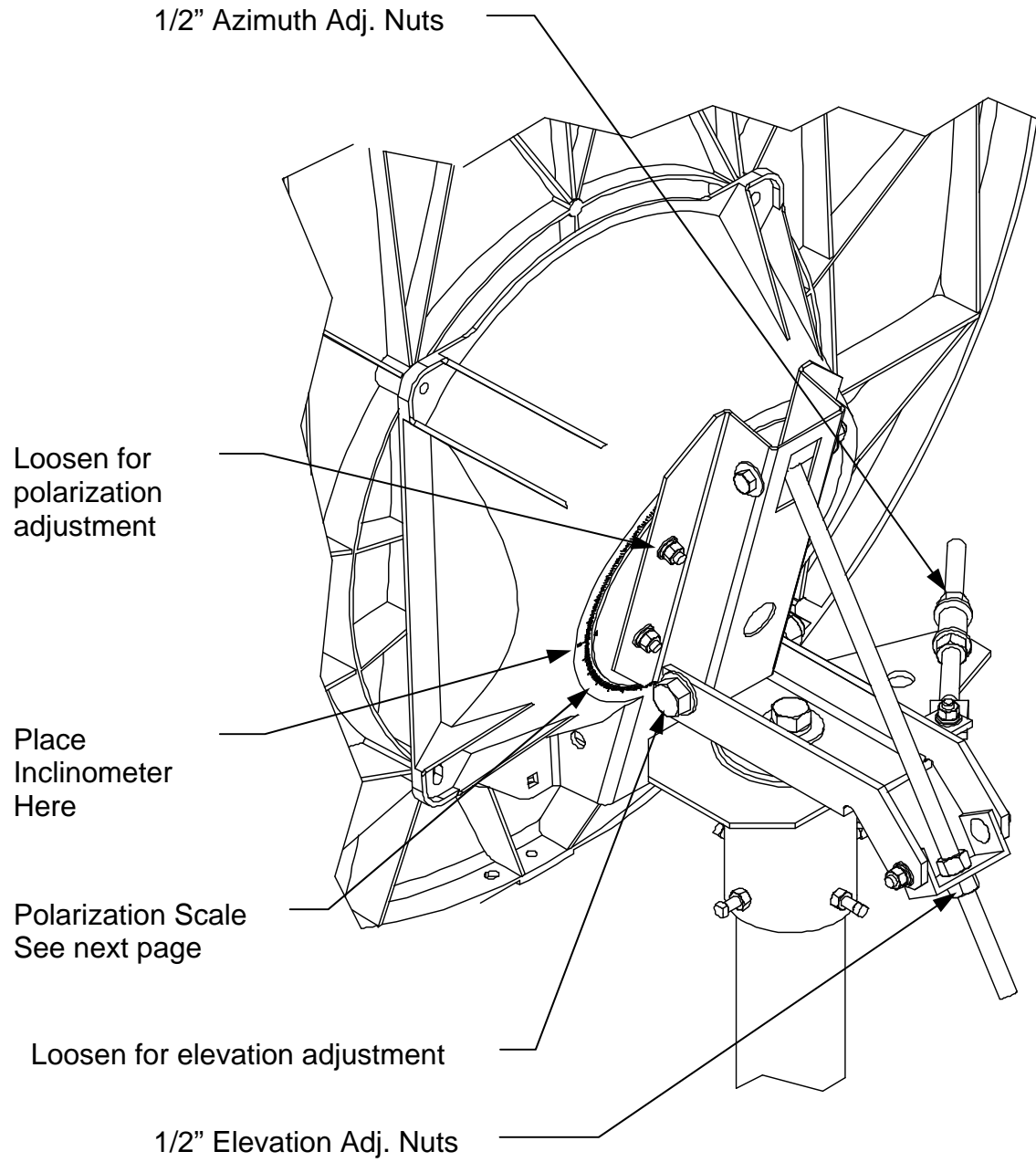
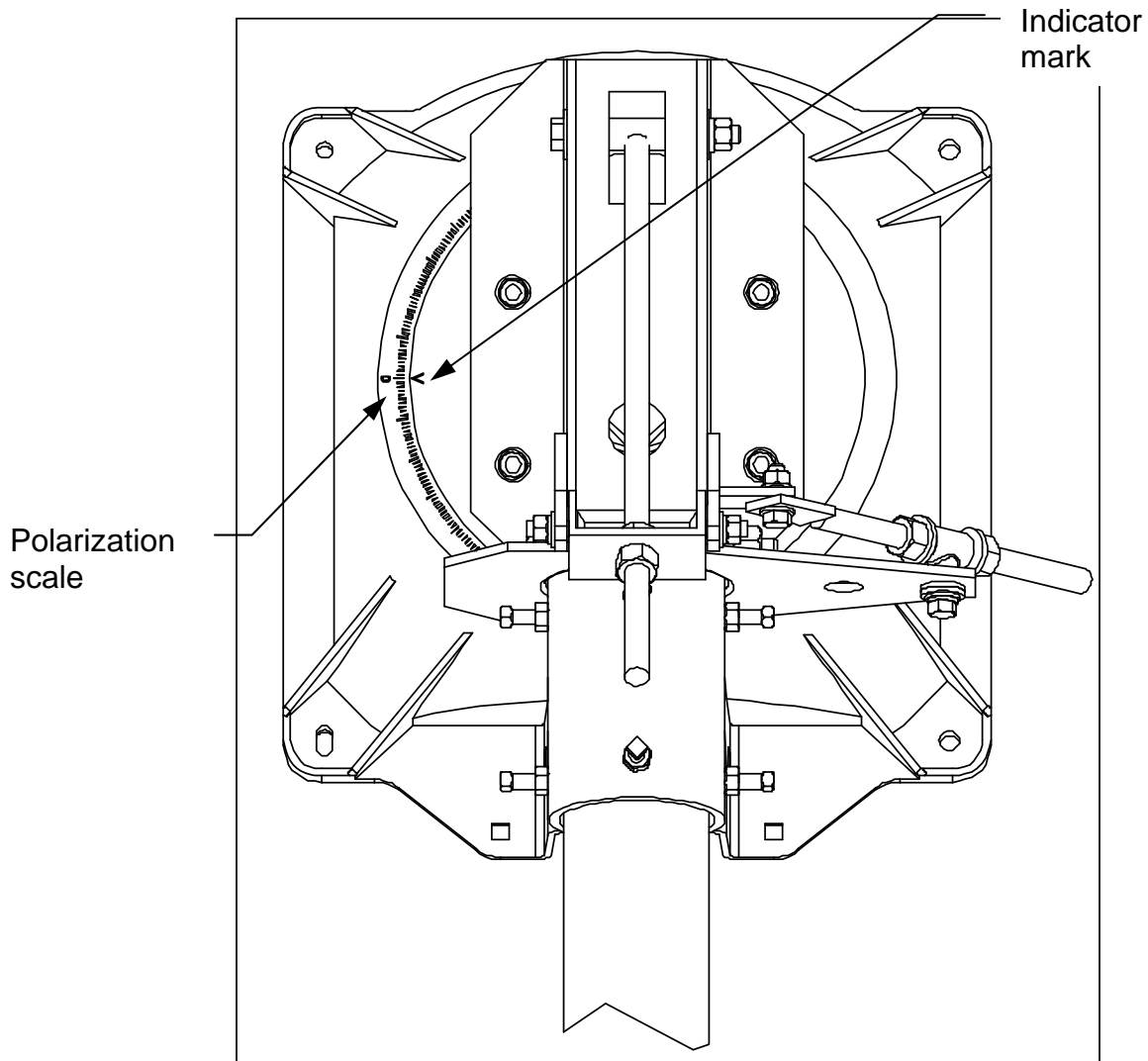

FIG. 8



**DETAIL VIEW OF POLARIZATION SCALE
FIG. 9**

SECTION IV MAINTENANCE

4.0 MAINTENANCE OVERVIEW

After installation, the antenna requires only periodic inspection. It is anticipated that maintenance, if required, will be minimal and easily handled by a local or in-house maintenance staff.

4.1 REFLECTOR

General Dynamics' reflector does not require any maintenance. The composite construction of the reflector is virtually impervious to any damages that could be caused by weather or atmospheric conditions. It is only necessary to inspect for any physical damage done by vandalism or very severe weather conditions.

Should any damage be detected to a portion of the reflector, contact the Customer Service Department at General Dynamics for recommendations involving reflector repair.

4.2 MOUNT AND REFLECTOR SUPPORT STRUCTURE

The mount and reflector support structure supplied with this antenna is of steel and aluminum construction and has a galvanized or chromate finish. If there are any signs of structural failure, the mount members that are damaged should be repaired or replaced.

4.3 FEED AND FEED SUPPORT

The feed support and feed rods should be inspected to insure that all hardware is secure. The feed/radio mounting bolts should be tight.

The feed horn window should be inspected to insure that it is intact so that no moisture can collect inside the feed horn.