

**GENERAL DYNAMICS**  
SATCOM Technologies

**4096-159**  
**REVISION H**  
**May 24, 2016**

**ASSEMBLY MANUAL**

**2.4M C-BAND Rx/Tx**  
**ANTENNA FEED SYSTEM**

**General Dynamics SATCOM Technologies**  
**1700 Cable Drive NE**  
**Conover NC 28613 USA**  
**Phone 770-689-2040**  
**[www.gdsatcom.com](http://www.gdsatcom.com)**

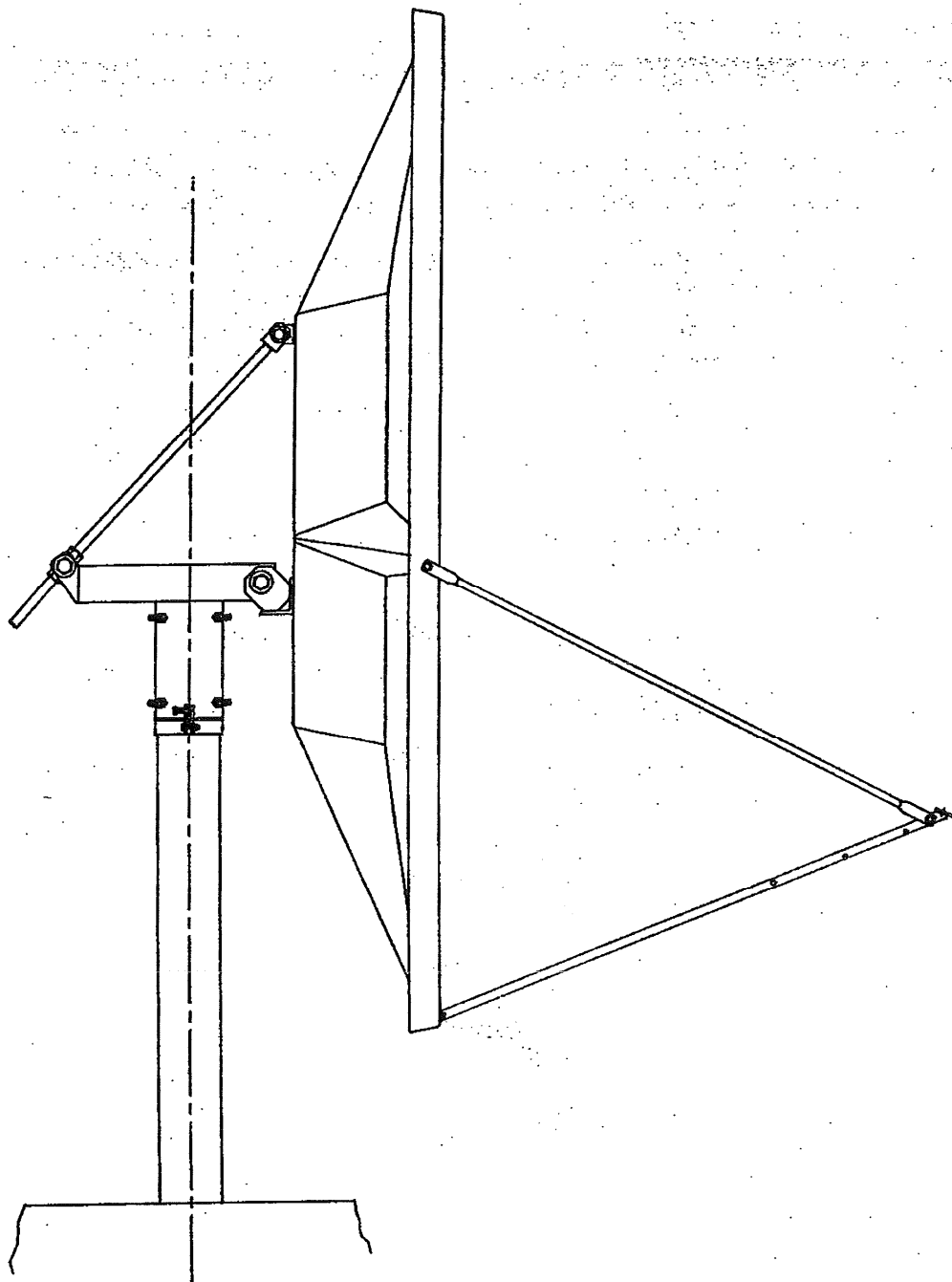

# 2.4M C-BAND Rx/Tx ANTENNA FEED SYSTEM

H	Add Conover Address	5/24/16	RAH
G	Revised Logo, name, and part numbers	5/12/09	RAH
F	Revise Text page 11	9/11/02	RAH
E	Revise Parts List - Feed Sprt table to match BOM	2/11/97	PGW
D		8/4/92	RF
-	ORIGINAL RELEASE	3/5/91	RF
<b>REV.</b>	<b>DESCRIPTION</b>	<b>DATE</b>	<b>APPROVED</b>

TABLE OF CONTENTS

<u>SECTION</u>	<u>TITLE</u>
<b>I</b>	<b>INTRODUCTION</b>
1.0	GENERAL INFORMATION
<b>II</b>	<b>FEED SUPPORT SYSTEM</b>
2.0	FEED SUPPORT ASSEMBLY
2.1	FEED ASSEMBLY
2.2	LNA/LNB ATTACHMENT
<b>III</b>	<b>FEED ASSEMBLY</b>
3.1	CROSS-POL & CO-POL
3.2	CIRCULAR POLARIZATION

## SECTION I INTRODUCTION

### 1.0 GENERAL INFORMATION

This manual describes the assembly and installation of General Dynamics' C-Band Rx/Tx Feed System. The General Dynamics C-Band Rx/Tx Feed System is a rugged, reliable antenna system, which will operate in the 3.7 to 6.425 GHz frequency bands with high efficiency and at the same time successfully withstand the effects of the environment.

## SECTION II FEED SUPPORT ASSEMBLY

### 2.0 FEED SUPPORT ASSEMBLY

As shown in figure 2.0-1, assemble the following items in the listed sequence. Do not tighten any hardware until step 4.

- Step 1: Attach a feed rod (item# 2) to each side of the reflector using a 3/8-16 x 1.25" bolt, [2] flatwashers, [1] lockwasher, and [1] hex nut (item# 3,5,6,7) for each rod. See detail "A".
- Step 2: Attach the other end of each feed rod to the feed support tube (item# 1) with the 3/8-16 x 3.00" bolt, [2] flatwashers, [1] lockwasher and [1] hex nut (item# 4,5,6,7). See detail "B".
- Step 3: Attach the feed support tube to the bottom of the reflector with [2] 3/8-16 x 1.25" bolts, [4] flatwashers, [2] lockwashers, and [2] hex nuts (item# 3,5,6,7). See detail "C".
- Step 4: Tighten all feed support hardware securely at this time.

PARTS LIST - FEED SUPPORT ASSEMBLY			
ITEM#	PART#	DESCRIPTION	QTY
1	Varies	FEED SUPPORT TUBE	1
2	Varies	FEED ROD	2
3	8032-010	BOLT, 3/8-16 x 1.25"	4
4	8032-024	BOLT, 3/8-16 x 3.00"	1
5	8201-042	FLATWASHER, 3/8"	8
6	8202-042	LOCKWASHER, 3/8"	5
7	8102-007	NUT, HEX, 3/8-16	5

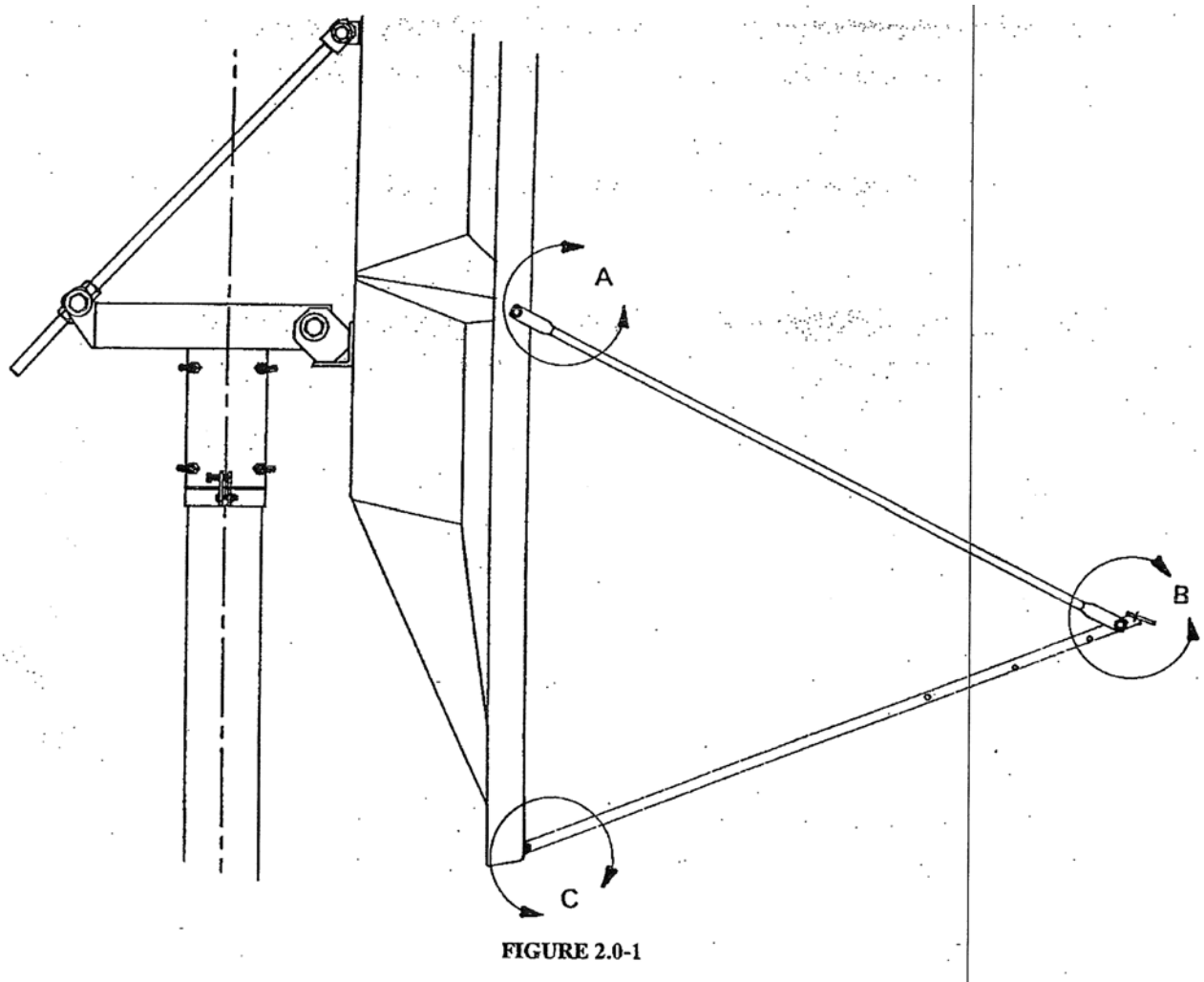
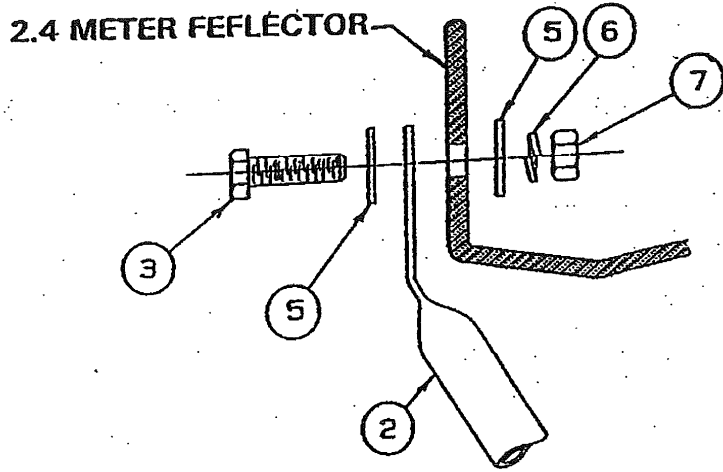
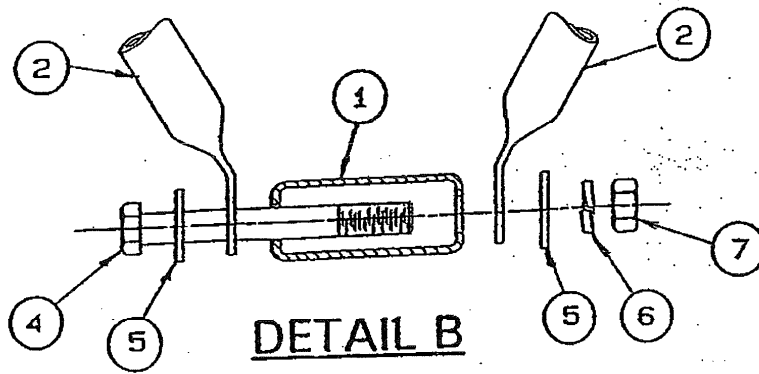

FIGURE 2.0-1



DETAIL A



DETAIL B

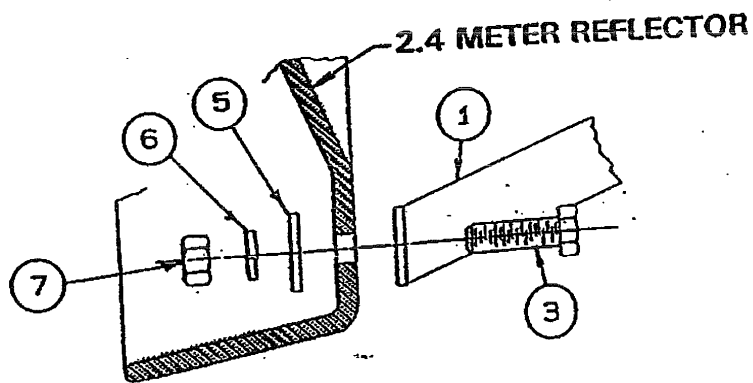

DETAIL C

## 2.1 FEED ASSEMBLY

**NOTE:** General Dynamics' 2.4 Rx/Tx antenna system is available with either Cross-Pol, Co-Pol, or Circular Polarization. Assembly of each feed configuration is outlined.

### 2.1-A CROSS-POL AND CO-POL FEEDS

Step 1: Apply silicone grease to the o-ring (item# 6) and place it in the groove in the OMT to be used. Mount the feed horn (item# 1) to the cross-pol OMT (item# 2) or co-pol OMT (item# 3) with [8] #10-24 x 1.25 screws, [16] #10 flatwashers, [8] #10 lockwashers, and [8] #10-24 hex nuts (item# 7,8,9,10). Tighten securely. **NOTE: The screws should be inserted from the feed horn side to prevent any interference.** See figure 2.1-A

Step 2: Attach the bottom feed mounting bracket (item# 4) to the feed support tube with [4] 3/8-16 x 1.25" bolts, [4] lockwashers, and [4] 3/8-16 hex nuts (item# 11,12,13). Tighten securely.

Step 3 : Place the neck of the feed horn/OMT assembly from step #1 into the feed mounting bracket and secure with the top feed mounting bracket (item# 5) using [2] 5/16-18 x 1.00" bolts, [2] lockwashers, and [2] 5/16-18 hex nuts (item# 14,15,16).

PARTS LIST - CROSS-POL & CO-POL			
<u>ITEM#</u>	<u>PART#</u>	<u>DESCRIPTION</u>	<u>QUANTITY</u>
1	0183-317	FEED HORN	1
2	0183-340	CROSS-POL OMT	1
3	0183-341	CO-POL OMT	1
4	0211-420	FEED MOUNTING BRACKET	2
5	0211-419	FEED MOUNTING BRACKET-TOP	2
6	0198-124	O-RING	2
7	302-007	#10-24 X 1.25 SCREW	8
8	8202-032	#10 LOCKWASHER	8
9	8111-005	#10-24 HEX NUT	8
10	8201-037	#10 FLATWASHER	16
11	8032-010	3/8-16 X 1.25" BOLT	4
12	8202-042	3/8" LOCKWASHER	4
13	8102-007	3/8-16 HEX NUT	4
14	8031-008	5/16-18 X 1.00" BOLT	2
15	8202-041	5/16" LOCKWASHER	2
16	8101-009	5/16-18 HEX NUT	2





## 2.1-B CIRCULAR POLARIZATION

- Step 1: Apply silicone grease to [2] o-rings (item# 7) and place [1] in the o-ring groove in the circular polarizer (item# 3). Attach the feed horn (item# 1) to the circular polarizer (end with o-ring) with [8] #10-24 x 1.25" screws, [16] flatwashers, [8] lockwashers, and [8] #10-24 hex nuts (item# 8,9,10,11). Tighten securely. **NOTE: The screws should be inserted from the feed horn side to prevent any interference.** See figure 2.1-B.
- Step 2: Bolt the OMT (item# 2) to the circular polarizer by placing the remaining O-ring in the groove of the OMT and fastening it to the circular polarizer with [8] #10-24 x 1.25" screws, [16] flatwashers, [8] lockwashers, and [8] #10-24 hex nuts (item# 8,9,10,11). **NOTE:** The screws should be inserted from the circular polarizer side to prevent interference. For left hand polarization, align the "LHCP" on the flange of the circular polarizer with the arrow on the OMT. For right hand polarization, align the "RHCP" with the arrow on the OMT. Tighten securely. **NOTE:** When a polarization setting is attempted, installers should keep in mind that right hand and left hand polarization refers to the transmission of signals from the feed to the reflector. Then the reflector reverses the signal. Therefore a "LHCP" feed system results in an antenna system that transmits a Right Hand Circular Polarized signal.
- Step 3: Attach [1] bottom feed mounting bracket (item# 4) and the circular polarizer bracket (item# 6) to the feed support tube plate with [4] 3/8-16 x 1.25" bolts, [4] lockwashers, and [4] hex nuts (item# 13,14,15) through the feed mounting bracket, circular polarizer and feed support, as shown, and [1] 5/16-18 x 3.25" bolt, [1] lockwasher, and [1] hex nut (item# 18,19,20) through the circular polarizer bracket and feed support tube only. Tighten securely.
- Step 4: Attach the remaining bottom feed mounting bracket to the circular polarizer bracket with [4] 3/8-16 x 1.00" bolts, [4] lockwashers, and [4] 3/8-16 hex nuts (item# 12,14,15). Do not tighten. **NOTE: Refer to figure 2.1-B to be sure that the brackets are oriented correctly.**
- Step 5: Place the feed assembly from step #1 into the brackets and secure by fastening [1] top feed mounting bracket (item# 5) over the neck of the feed horn with [2] 5/16-18 x 1.00" bolts, [2] lockwashers, and [2] hex nuts (item# 16,19,20). Fasten the remaining top feed mounting bracket over the neck of the circular polarizer with [2] 5/16-18 x 1.50" bolts, [2] lockwashers, and [2] hex nuts (item# 17,19,20). Tighten the feed mounting bracket (from step #4) to the circular polarizer bracket. The antenna system is now ready to be aligned to the satellite.

<b>PARTS LIST</b>			
<b>CIRCULAR POLARIZATION</b>			
<b><u>ITEM NO.</u></b>	<b><u>PART NO.</u></b>	<b><u>DESCRIPTION</u></b>	<b><u>QUANTITY</u></b>
1	0183-317	FEED HORN	1
2	0183-341	CROSS-POL OMT	1
3	0182-191	CIRCULAR POLARIZER	1
4	0211-420	FEED MOUNTING BRACKET	2
5	0211-419	FEED MOUNTING BRACKET- TOP	2
6	0181-719	CIRCULAR POLARIZER BRACKET	1
7	0198-124	O-RING	2
8	8302-007	#10-24 X 1.25" SCREW	16
9	8202-032	#10 LOCKWASHER	16
10	8111-005	#10-24 HEX NUT	16
11	8201-037	#10 FLATWASHER	32
12	8032-008	3/8-16 X 1.00" BOLT	4
13	8032-010	3/8-16 X 1.25" BOLT	4
14	8202-042	3/8" LOCKWASHER	8
15	8102-007	3/8-16 HEX NUT	8
16	8031-008	5/16-18 X 1.00" BOLT	2
17	8031-012	5/16-18 X 1.50" BOLT	2
18	8031-026	5/16-18 X 3.25" BOLT	1
19	8202-041	5/16" LOCKWASHER	5
20	8101-009	5/16-18 HEX NUT	5

### CIRCULAR POLARIZATION

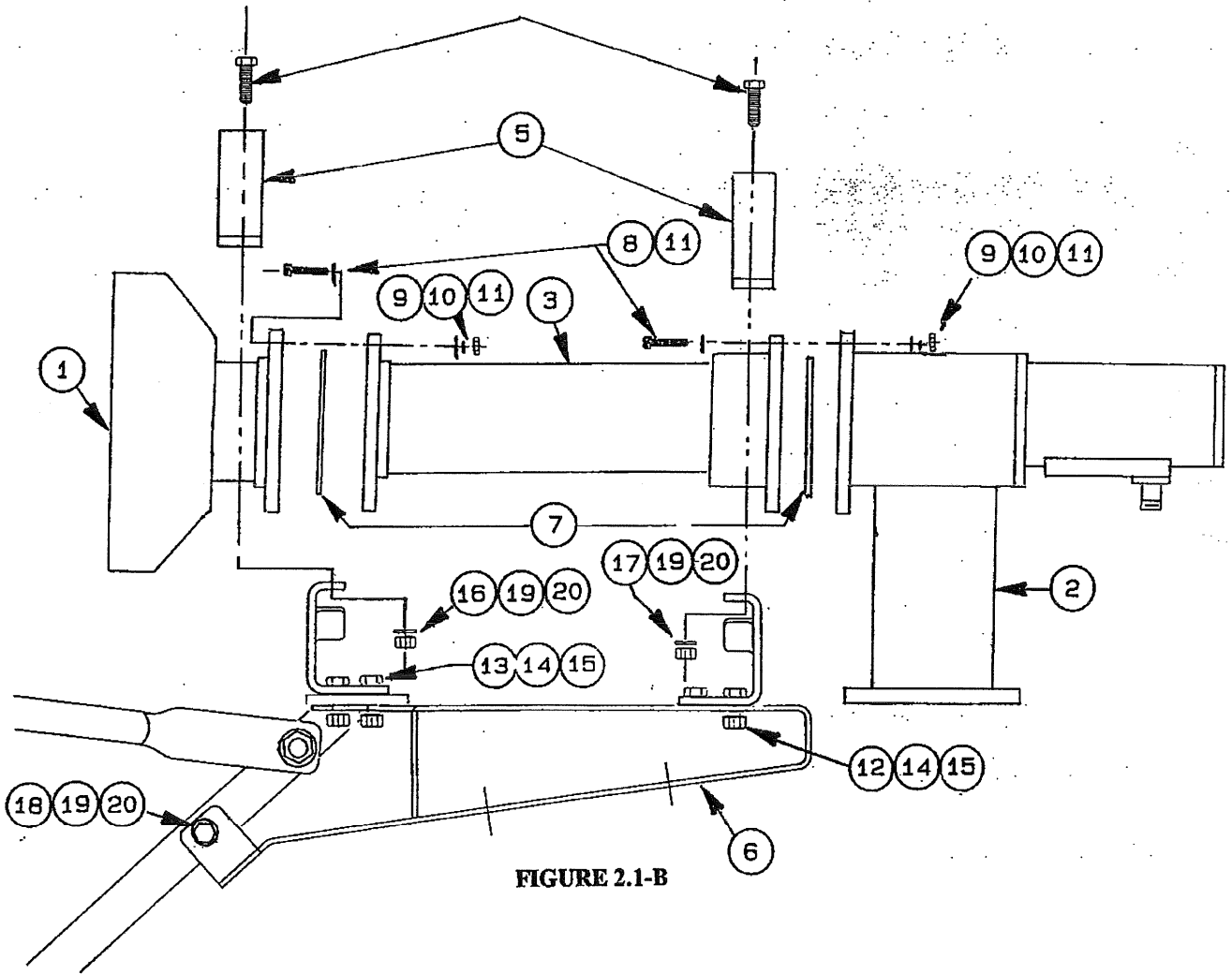
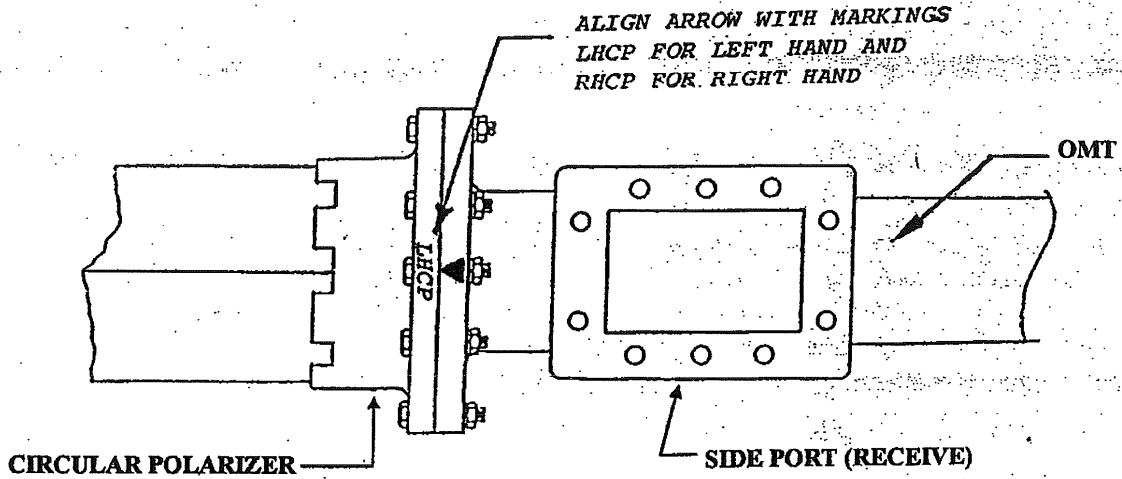

FIGURE 2.1-B

**2.2 LNB/LNA ATTACHMENT**

**STEP 1.** Apply silicone grease to gasket (item#1) and place gasket in groove in flange of LNA/LNB (customer supplied).

**STEP 2.** Attach LNA/LNB to side port (Rx) flange of OMT with (10) 1/4-20 x 1.00" bolts, (10) 1/4" flatwashers, (10) 1/4" lockwashers, and (10) 1/4-20 hex nuts (item# 2,3,4,5).

**STEP 3.** Tighten 1/4" hardware securely.

PARTS LIST - FEED SUPPORT ASSEMBLY			
ITEM#	PART#	DESCRIPTION	QTY
1	0171-073	GASKET, CPR WR2296 FLANGE HALF-THICK	1
2	8023-008	BOLT, 1/4-20 X 1.00" TYPE 304 S.S. STD.	10
3	8201-036	FLATWASHER, 1/4" S.S. STD.	10
4	8202-031	LOCKWASHER, 1/4" S.S. STD.	10
5	8100-005	NUT, HEX, 1/4-20 S.S. STD.	10

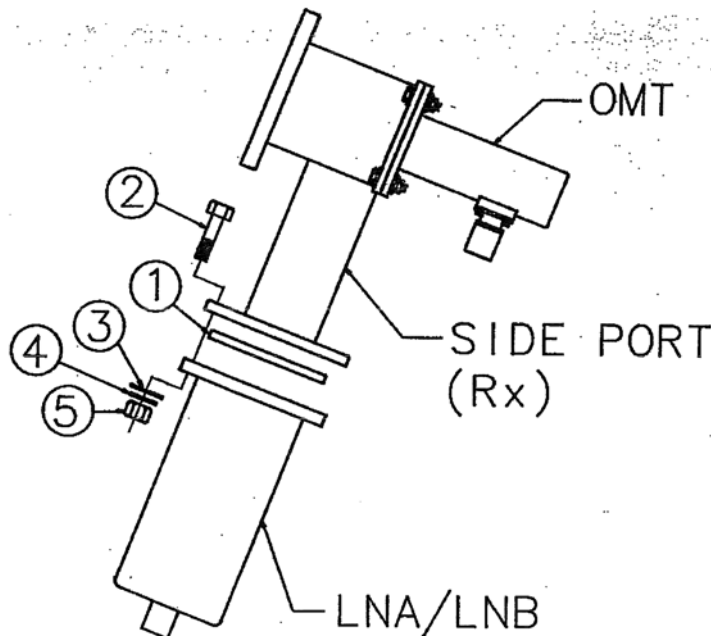

FIGURE 2.2-1